

AKW M17 DIGIPUMP

Installation and User Care Instructions



Read ALL instructions carefully BEFORE installation and leave with the end user for future reference



CE

| | |
|---|-------|
| Introduction-Declaration of Conformity | 2 |
| Box Contents -Plumbing Specification | 3 |
| Important Safety and Electrical Information | 4 |
| Product Specifications | 4 |
| Fixing pump to surface | 5-7 |
| Plumbing connections | 8 |
| Fitting Flow Sensor(s) | 9 |
| Electrical Installation | 10-11 |
| Pump Set Up | 12-13 |
| Commissioning | 14 |
| Care and Maintenance | 15 |
| Problem Solving | 16 |
| Warranty | 17 |

M-SERIES DIGIPUMPS

The M series DigiPump and sensor kits has been designed for the pumping of shower waste water. The DigiPump control unit uses flow sensors to measure the flow rate of water into the shower. The control unit uses the signals sent from the flow sensors to adjust the pump speed automatically to match the flow of water from the shower. When the shower is turned off, the flow sensors send a signal to the control unit and after a pre-set time delay the pump turns off. After a further set time the pump will automatically switch on for a short period of time at a reduced pumping speed, removing any run off water pooled in the shower area and gully. The pump has the ability to run dry without causing damage. Non-return valves in the pump head prevent smells from entering the bathroom area from the waste pipe.

Declaration of Conformity

We declare that the AKW M17 DigiPump shower waste water pump conforms to the requirements of the EMC Directive 2014/30/EU, LVD Directive 2014/35/EU and the following harmonised European and national standards in the confirming assessment.

EN 60335-1
EN 60335-2-41
EN 62233
EN 61000-3-2
EN 61000-3-3
EN 55014-1
EN 55014-2











AKW Ltd.

Before you start...

Confirm you have all the correct parts and tool required.

Box contents

| | | | | | |
|----|---|---------|---|----|---|
| 1x |  | 2x 22mm |  | 1x |  |
| 3x |  | 2x 22mm |  | 1x |  |
| | | | | 2x |  |
| | | | | 3x |  |

Plumbing Specification

This product is rated at IP45 and suitable to be installed in Zone 1, 2 or Zone 3 of a shower room only if these instructions are fully complied with.

The unit must be located away from the direct line of water jets.

Note: Zone 1 lies above zone 0 and upto 2250mm (88in) vertically above a shower tray or wet floor area.

The perimeter of zone 1 of a wet floor is within a 1.2 metres (47in) radius of the shower head position. Zone 2 is the area 600mm beyond Zone 1.

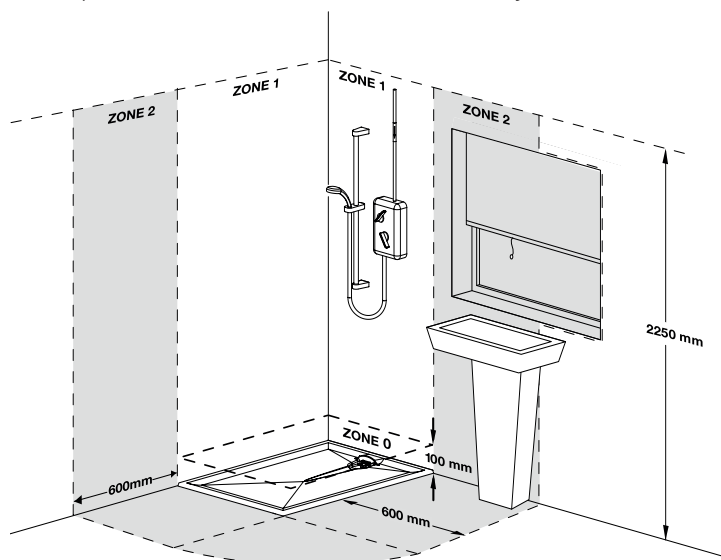

FOR GUIDANCE ONLY - PLEASE REFER TO BS7671 FOR FURTHER DETAILS

Important Safety & Electrical Information

THIS CLASS II APPLIANCE DOES NOT REQUIRE AN EARTH



CAUTION: 230V AC
Lethal Voltage present on the AC supply



Ensure mains power supply is switched OFF before starting wiring



DO NOT take risks with plumbing or electrical installation. This product must be installed and serviced by a competent person in accordance with the current edition of the Wiring Regulations (BS7671), local by-laws and the current building regulations.



This product must be installed, used and maintained in good working order in accordance with these instructions and recommendations.



If the supply cord is damaged, it MUST be replaced in order to avoid hazard.

The 230V AC power supply to this unit must be provided via a two-pole isolator switch and a dedicated circuit with a 30mA RCD device installed in accordance with the latest revision of the Wiring Regulations BS7671. It must be wired into a fused, unswitched, fixed wiring connector fitted with a 5 amp fuse.

The IP45 rating of the AKW pump product refers to the inner casing containing the electrical control gear. The pump motor which operates at SELV is located within the outer cover.

Product Specifications

AKW M17 DigiPump high performance shower waste water pump.

Pump Specification:

SUPPLY: 230V AC 50Hz 100W

IP45

DUTY CYCLE: 50% max 30 mins on.

Quiet in operation.

For use with electric & mixer showers.

Pump and controller enclosed in one unit.

Max flow rate: 17 Litres Per Minute (LPM).

Non-handed, selectable inlet/outlet direction.

Note: Increased Head/Lift conditions will affect the pump's performance.

Pump Capacity:

17 LPM MAX under head/lift conditions.

Derate accordingly for installed conditions.

Max Head: 1.0m (39in).

Max Lift: 0.5m (20in).

MAX COMBINED HEAD + LIFT:
1.5m (59in).

Fixing pump to surface

Important: For service & maintenance purposes this product should be installed in an accessible location.

The pump unit must be located on a vertical surface with the inlet/outlet connections at the bottom of the unit in horizontal alignment, with the AKW case logo at the top.

Pipe connections must be easily accessible and a clearance of 100mm around the base and sides is recommended.

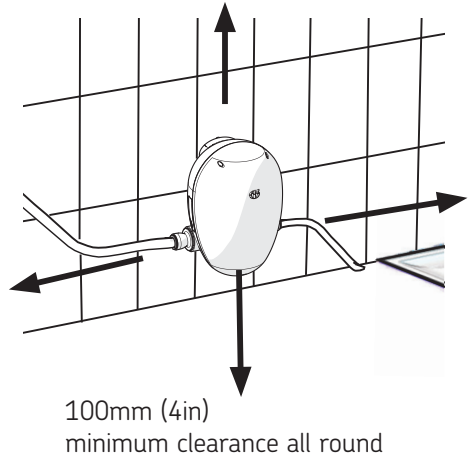

Fitting Pump Spacers

Use the Pump Spacers to prevent the cables being trapped.
Separate the spacers, remove the adhesive backing and snap lock into position

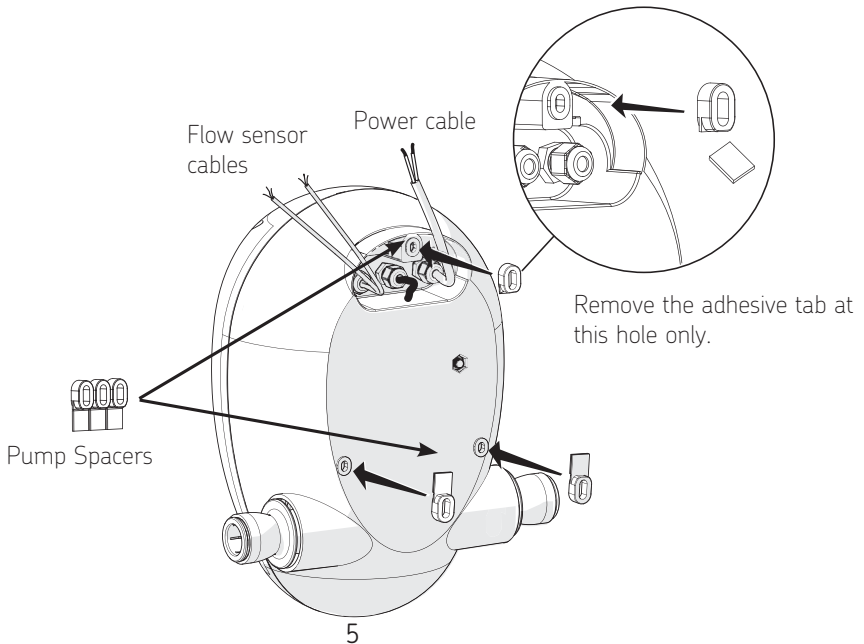

Fixing pump to surface

- 1 Remove front cover with a screwdriver.

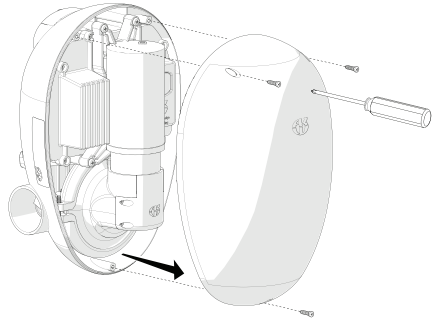

- 2 Disconnect pump motor cable. Remove pump assembly from the back plate to access the fixing holes.

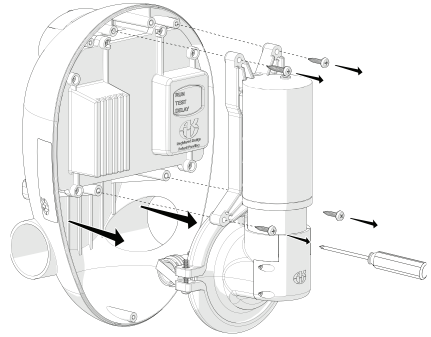

- 3 Fit to a finished surface. Using the back plate as a template mark the fixing holes. Drill and plug the wall taking care there are no hidden cables or pipes. Use all the screw fixing positions.

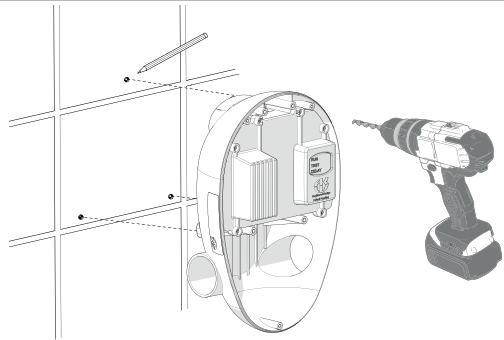

- 4 Mount the pump to the finished surface using all the wall fixings. Use the Pump Spacers to prevent the cables being trapped. See pump spacers fitting.

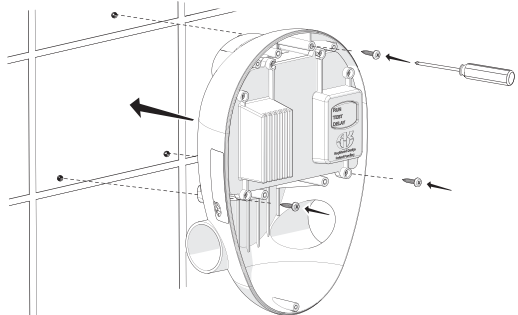

Fixing pump to surface

- 5 Check that the flow is in the required direction, reverse as required. Loosen the pump head housing, rotate and fully tighten home. The pipework to this high performance pump must be clamped down effectively, AKW advise and recommend you clamp pipework either side of joints, junctions or connections and at a maximum of 500mm between other supports.

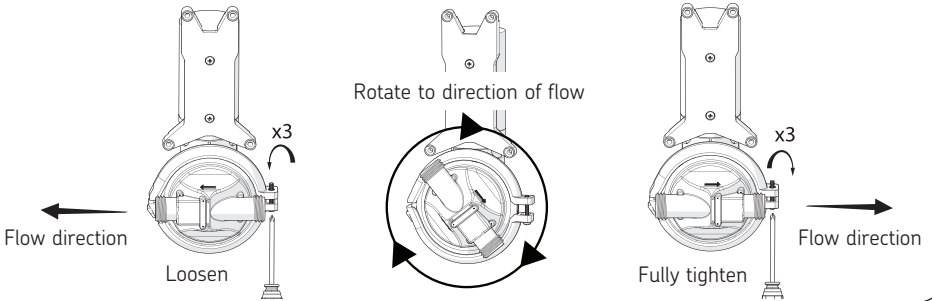

- 6 Remove shipping tapes from pump inlet and outlet. Refit the pump to the back plate. Reconnect pump motor cable.

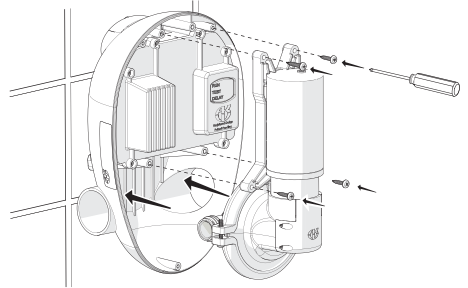

- 7 Fit the non-return valves as shown. Fit the pump connectors to the pump. Screw both connectors into place. No thread sealant needed, firmly hand tighten only.

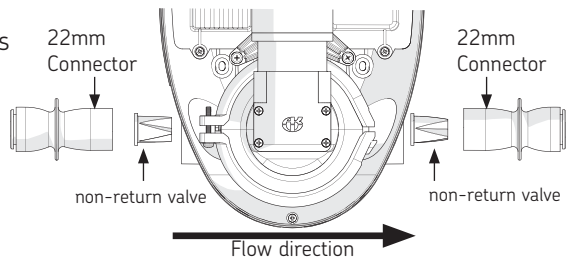

- 8 Check that you have not overtightened and distorted the non-return valves before connecting the pipework. Refit the front cover.

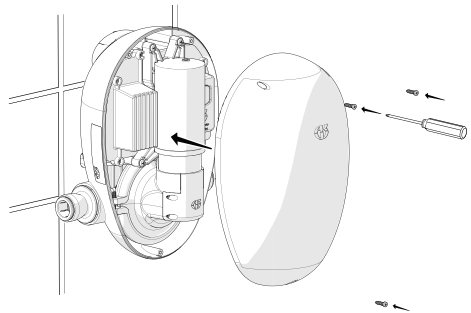

Plumbing Connections

For best performance locate within 1m (39in) of shower and minimise the number of lifts, bends and the length of all pipes connecting the pump to the waste outlet pipe.

Note: Increased Head/Lift conditions will affect the pump's performance. See product specifications.

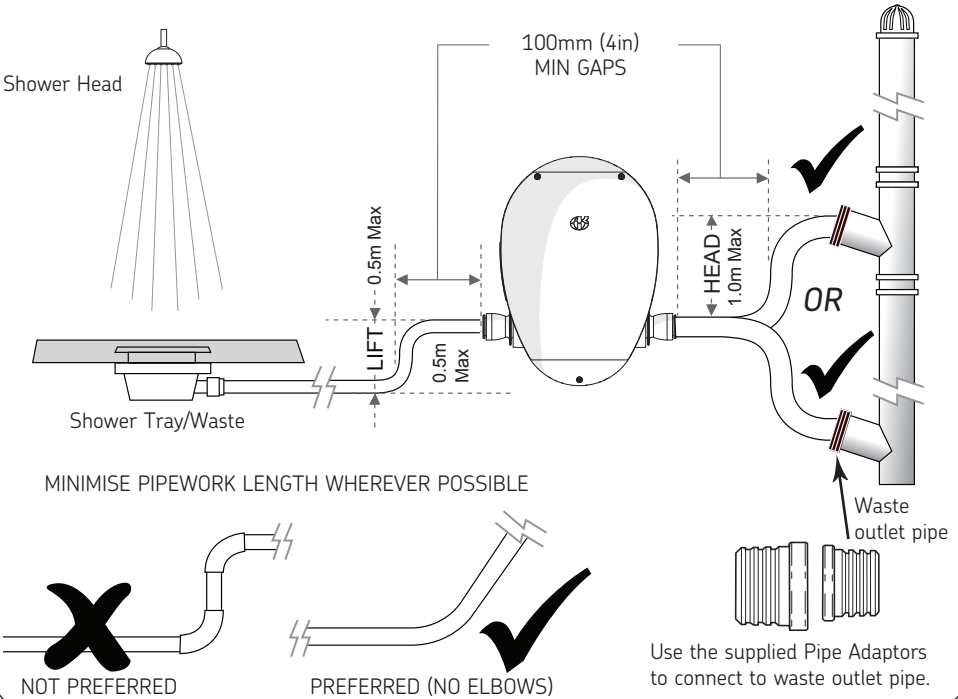
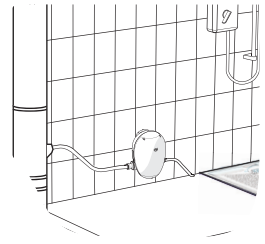

Important: Pipe connections must be easily accessed and pipework must be secured to prevent vibration and noise.

NEVER fit pipe inserts.

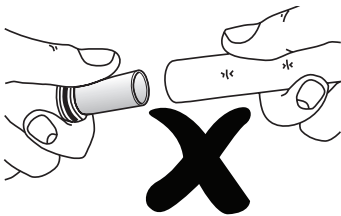

ALWAYS fit the supplied collet locking clips.

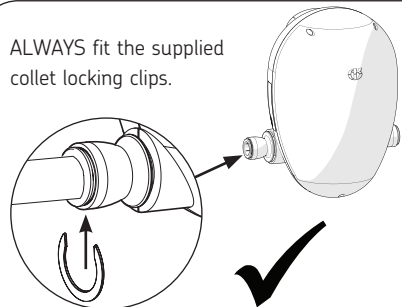

Fitting Flow Sensor(s)

Depending on the installation install 1 or 2 filters and sensors to the shower water feed. Install the filter (Y-Pattern filter) in the correct flow orientation to the shower water supply line and then fit the flow sensor between the filter and the shower.

Confirm shower water supply pipework is flushed before connecting to the shower sensor via the filter.

Electric showers have one water supply line, cold water. Fit one Filter and Flow Sensor to this line.

Mixer showers have two supply lines, hot and cold water. Fit one Filter and Flow Sensor to each supply line.

Double check direction of the flow arrow moulded on the sensor casing is in the correct orientation with the flow of water. Allow enough distance so that the sensors are easily accessible. Ensure all cable connections are accessible and in a dry location. Fit sensor using an approved liquid based thread sealant suitable for nylon threads. Connect the sensor tail cable from the flow sensor to the pump sensor cable (see page 11). **Do not tile over the flow sensors and filters and ensure they are accessible for service and maintenance purposes.**

Vertical Water Feed Installation

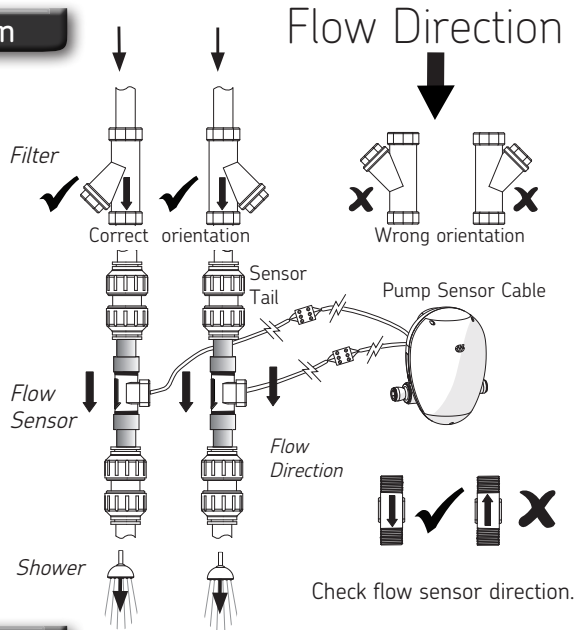
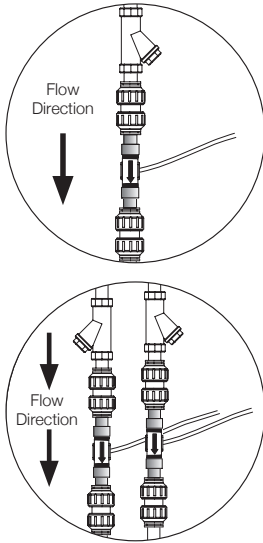

Horizontal Water Feed Installation

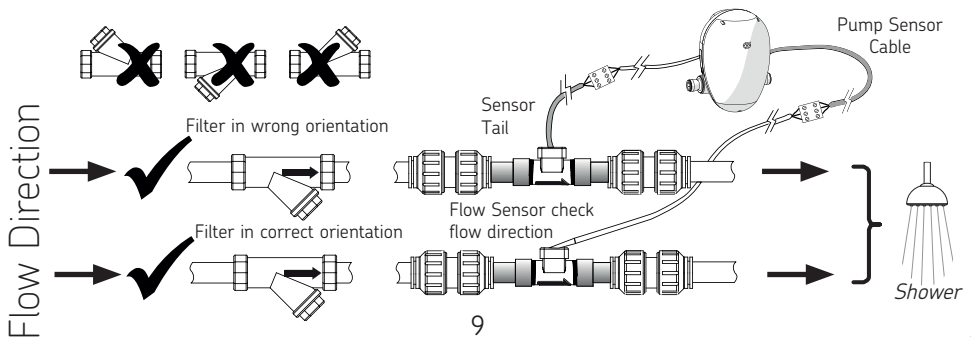

Electrical Installation



Ensure Mains Power Supply is Switched OFF before starting wiring.



DO NOT take risks with Plumbing or Electrical Installation.

Only a competent trades person should attempt this installation.

This product is rated at IP45 and may be installed in Zone 1, 2 and 3 of a shower room only if the following conditions are fully complied with.

The pump unit must be located on a vertical surface with the inlet/outlet connections at the bottom of the unit in horizontal alignment, with the AKW case logo uppermost.

The unit must be located away from the direct line of water jets whenever possible.

Cable to and from the pump must be run directly out of zone 1 by the shortest route below the unit or directly behind into the vertical surface. All such routes must be sealed to prevent water ingress.

Cables routed from above, down into the device, act as a drip path and should not be used.

Cables must be protected against mechanical damage and sealed against water ingress.

The case must not be cut except for the thin rear shroud. Do not pierce casing. Use the supplied Pump Spacers kit to route the cables behind the unit.

The clearance behind the unit and separation from the wall must be minimal and the gap must not be sealed.

All casing cable glands must be visually checked for presence of the elastomeric centre sealing grommet and tightness checked and confirmed before installing against the wall.

No cable joints may be made in zone 1.

The unit inner cover must not be disturbed and the outer cover must be correctly fitted.

The 230V AC power supply to this unit must be provided via a two-pole isolator switch and a dedicated circuit with a 30mA RCD device installed in accordance with the latest revision of the Wiring Regulations BS7671. It must be wired into a fused, unswitched, fixed wiring connector fitted with a 5 amp fuse.

The IP45 rating of the AKW pump product refers to the inner casing containing the electrical control gear.

The pump motor which operates at SELV 32 DC (maximum) is located within the outer cover.

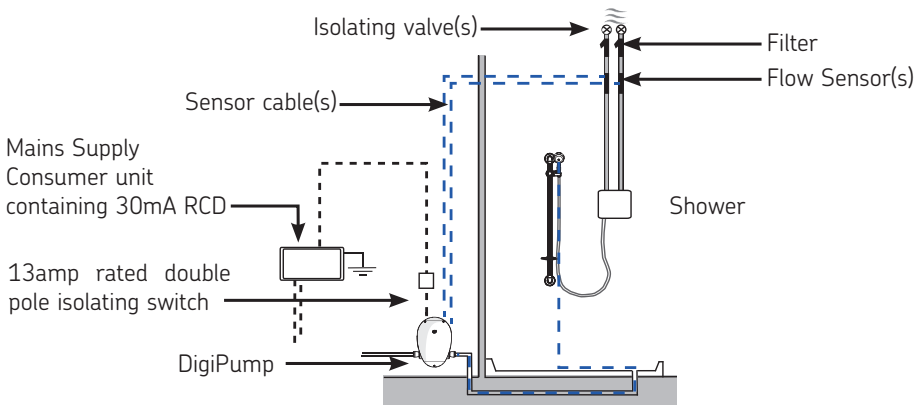

Connecting the Flow Sensor(s) to the Digipump

Ensure sensor and filter are in an easily accessible location.

Ensure all cables and plumbing are behind water resistant surfaces.

The pump has two flow sensor cables, for mixer showers with two water feeds, both must be connected to the separate flow sensors. Fit one flow sensor to cold water feed pipe and one to the hot water feed pipe.

For electric showers only connect one sensor, the other sensor wire must be terminated in a connector block and insulated using electrical insulation tape at a dry location.

Failure to do this may damage the pump.

Note: To connect the pump directly to a compatible electric shower please see the instructions supplied with your electric shower.

All cable connections must be in a dry location.

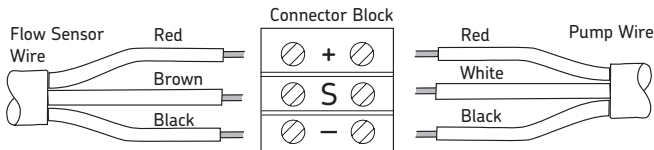

Ensure the pump spacers are used to prevent the cables from being trapped.

Pump Set Up

Control Button Description

Top Button = **RUN** (Sets shower stop run-on time)

Centre Button = **TEST** (Calibration)

Bottom Button = **DELAY** (Sets shower start delay to run)

RUN
TEST
DELAY

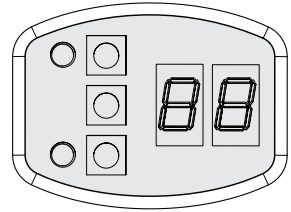

Calibration

The AKW DigiPump allows for precise pump control of the shower waste water by calculating the amount of water the shower is producing. It may be necessary to calibrate the pump once installation is complete (the pump may be over or under pumping).

Before calibration, the correct flow sensor pulse rate must be set. See Pump Settings - Sensor type.

Run the shower at the expected normal flow rate. The pump must run at a speed which removes the same amount of water as is flowing in.

Adjust the calibration value so the water level stays approximately the same. If the water level drops, decrease the value on the display so the pump runs slower. If the water level rises, increase the value on the display so the pump runs faster. When the value is set correctly, press the test button to store. The controller will then return to its normal operating mode.

Timer Adjustment

With the pump in normal operating mode and the LED showing the run on time ...

Adjust Run on time. (the time the pump will run after the shower has stopped)

Press the RUN button: this will increase the time by 1 second, holding the button will increase the time rapidly. Once the time reaches 99 it will roll over to 01.

Adjust Start Delay (the time before the pumps starts after the shower is operating)

Press the DELAY button: this will increase the time by 1 second, holding the button will increase the time rapidly. Once the time reaches 99 it will roll over to 01.

Pump Settings

When power is applied to the pump, the display will briefly indicate the model and software version of the pump (00-M11 : 01:M17 : 02:M20)

The pump will then enter standby mode.

In Standby Mode ...

The 'RUN' led will be lit, indicating mains voltage present.

The display will indicate the 'run-on timer' setting in seconds (factory default 20).

Setup

=====

SENSOR TYPE (range 00 to 03) default 02

From standby ...

Press and hold the TEST button until the RUN led flashes

00 : Relay

01 : 600 pulses per litre

02 : 1000 pulses per litre (default)

03 : 2200 pulses per litre

RUN button

Short press : increase (single)

Long press : increase (repeating)

DELAY Button

Short press : decrease (single)

Long press : decrease (repeating)

Press the TEST button to save settings and enter calibration mode

CALIBRATION (range 00 to 99) default 50

RUN button

Short press : increase (single)

Long press : increase (repeating)

DELAY Button

Short press : decrease (single)

Long press : decrease (repeating)

Press the TEST button to save settings and exit calibration.

=====

START DELAY (range 01 to 99) default 05 seconds

From standby ...

DELAY button

Short press : value single increment

Long press : value repeating increment

Press the RUN button to save settings and enter standby mode.

=====

RUN-ON TIME (range 01 to 99) default 20 seconds

From standby ...

RUN button

Short press : value single increment

Long press : value repeating increment

Pump is in standby mode.

=====

TEST SEQUENCE

From standby ...

Press the 'TEST' button

The 'DELAY' led will start flashing

The display will indicate the 'start-delay timer' setting in seconds (factory default 05).

The display will count down to zero

The pump will start

The display will indicate the time left to run in seconds

When the display reaches zero the pump will revert to standby mode.

This test can be carried out with or without water present and also the sensor fitted or not.

Commissioning Checks

As a general precaution and check before installation, always ensure the supply pipework to the shower has been fully purged with at least 20 litres (2 buckets) of water through it before the flow sensor is installed. Any building debris in the water supply will adversely affect the sensor function and may also damage the shower heater/mixer.

*Install pump according to these instructions. Failure to do so may void warranty.
Confirm all push-fit pipes are fully inserted 20mm into fittings.*

*Brush out all dust, grit and debris
from shower tray*

Thoroughly clean out waste

*Confirm shower water supply pipework is flushed
before connecting to the shower sensor via the filter*

Turn on power to Pump

*Turn shower on Low Flow and confirm pump
operates after Start Delay (default 5 secs.)
Run for 2-3 mins*

Set shower to Maximum Flow

*Follow the Calibration setting, adjust pump speed on
controller to match maximum shower flow*

*Switch shower OFF.
Pump will RUN-ON*

*Adjust RUN-ON and repeat until tray is cleared and
pump stops with minimum RUN-ON*

*If you experience problems see
Problem Solving section*

Care and Maintenance

The integrity of the case and the RCD device operation should be checked quarterly as part of a routine safety and maintenance activity on the installation.

If the case shows any mechanical damage the unit must be isolated electrically and the entire unit replaced.

Pipework connections must be made to the unit with sufficient clearance (100mm minimum separation to any pipe bend or fitting adjacent to the inlet/outlet connections) to permit removal of the pump/head for routine maintenance and replacement.

The unit must be regularly cleaned using normal bathroom cleaning materials and rinsed down with clean water and wiped dry with a soft cloth to remove any cleaning residue.

Do not use strong or concentrated acidic or alkaline cleaning materials as these may discolour or otherwise damage the product. Do not use an abrasive cloth.

Installation Problems

PUMP WILL NOT START

```
graph TD; A([PUMP WILL NOT START]) --> B[Please refer to pump instructions to ensure the pump is installed correctly.]; B --> C[Ensure flow sensor is connected to pump controller and power is on to pump controller.]; C --> D[Ensure that all pipe work is fully flushed before the flow sensor is installed, and the in-line filter is in place. Check flow sensor is installed in the correct orientation (Flow direction arrow moulded on the casing). Most flow sensor problems are due to debris being caught inside the flow sensor. Remove sensor and check for debris. If required reverse flush with water.];
```

Please refer to pump instructions to ensure the pump is installed correctly.

Ensure flow sensor is connected to pump controller and power is on to pump controller.

Ensure that all pipe work is fully flushed before the flow sensor is installed, and the in-line filter is in place.

Check flow sensor is installed in the correct orientation
(Flow direction arrow moulded on the casing).

Most flow sensor problems are due to debris being caught inside the flow sensor.

Remove sensor and check for debris.

If required reverse flush with water.

PUMP WILL START BUT DOES NOT PUMP WATER

Check Non-Return Valves are correctly fitted and oriented in the inlet and outlet pipe connectors.

Confirm plastic pipe inserts are **NOT** used. (see page 9 installation)

Ensure all push-fit pipe connections are fully sealed and O-rings are not damaged or displaced.

The water pumping capacity can be adjusted by adjusting pump speed. Adjust pump speed using the calibration setting. Please refer to pump set up.

When increasing the pump speed, if the pump still performs low or no suction, take off the pump head by removing the clamp ring. Examine the inlet and outlet flap valves for traces of hard debris such as grit. If so, wash out all debris and ensure the non-return valves are seated correctly.

If problem persists, check all connections for air leaks or blockage in either the inlet or outlet pipework. Repair any leaks and clean blockages.

PUMP WILL NOT STOP

The pump has an overrun timer to allow it to continue to run after the shower has been switched off. This timer is factory set to 20 seconds.

With the power supply switched on, disconnect the flow sensor. Separate the disconnected wires. This will simulate the flow sensor turning off. Pump should stop after the overrun time. If not, check the controller display panel or cabling. If the pump has not stopped, disconnect power supply and contact customer services.

Is the controller working, remove and check the flow sensor, flush it through with water or replace it as necessary.

Warranty Information

Warranty is in addition to your statutory and other legal rights. Warranty becomes effective from date of installation. To validate and start the warranty, you must return your completed warranty registration card and return it in the prepaid envelope or alternatively visit the AKW website and complete the online registration form for your product.

Refer to the product identification label on the outer case of the product or the outer packaging for product details.

Warranty applies to all moving and serviceable parts against any manufacturing defects, faulty materials or poor workmanship.

Warranty covers your shower waste water pump against any defect in materials or workmanship for 5 years from the date of installation. Within this period we will resolve defects free of charge by repairing or replacing as we may choose.

To be free of charge work must only be undertaken by AKW or our approved agents in the UK or the Republic of Ireland and with prior agreement.

Any action taken under this warranty does not extend the stated 5-year expiry date.

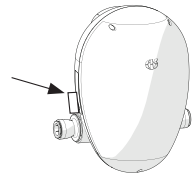

Locate the product identification label

NOT COVERED BY THIS WARRANTY

Warranty excludes general wear and tear through usage and this does not apply to inappropriate use, inappropriate cleaning, damage or defects that result from unauthorised modifications or repairs, accidental damage, lack of maintenance including the build up of grime, dirt, limescale, waterborne debris or from water freezing damage. Damage caused by the use of other products with the M series Digipumps that are not shown in this manual.

This does not cover components that are subject to general wear and tear such as filters, seals, O-rings and washers or non-return valves.

Servicing should be carried out at regular intervals of no more than 12 months and more frequently in hard water areas (heavy lime scale areas). In the unlikely event that any problems are encountered with the product's performance on installation, you must obtain guidance/authorisation from our Technical Team Department and be able to supply proof and date of purchase before any action is taken.

WHAT TO DO IF SOMETHING GOES WRONG

If your shower does not work correctly first follow the **Problem solving** chart on page 16, then contact your installer. Should this not resolve your problem, contact AKW technical helpline.

Important Safety Information

✓ **ALWAYS** read these installation instructions carefully before installing this product and leave with the end user for future reference.



Lethal Voltage present on the AC supply to the pump inner case. This unit must be connected to a double-pole switched supply, suitably fused and provided with a RCD protection.



This product must be installed by a qualified and competent person and in accordance with the current edition of the Wiring Regulations BS7671.



This appliance must be located to comply with the safety zones as defined in the wiring regulations.



Isolate this unit before access for maintenance or any other purpose. Do not immerse in water.



There are no user serviceable parts within case.

The cover must only be removed by an competent person or electrician.



Caution! Always check for electric cables and water pipework before cutting into walls, floor boards or drilling into surfaces.

Technical Help line
01905 560219

Orderline
01905 823299

General Enquiries
01905 823298

Fax
01905 823297

Website
www.akw-ltd.co.uk

Quotes & orders email
orders@akw-ltd.co.uk

Enquiries email
sales@akw-ltd.co.uk
technicalenquiries@akw-ltd.co.uk

Post
AKW, Pointon Way,
Hampton Lovett,
Droitwich Spa,
WR9 0LR



For the latest AKW product news scan this QR code with your device.

What to do if something goes wrong?

In the event that you should encounter a problem with this product, please contact your local installer and if this does not resolve the issue, then contact AKW technical team who will provide further advice and, if necessary, arrange for a maintenance engineer to visit and report any issues.

As part of our quality and training program, calls may be monitored or recorded. None of the foregoing affects your statutory rights.

These instructions are provided to advise the minimum standards of installation and recommends what the best practice for the installation is. Due to the very wide variability of possible installation conditions, AKW cannot provide all circumstances for the installation. AKW cannot accept any liability in connection with this information or its use. This information is provided on the condition that the person receiving it shall make his/her own tests to determine the suitability for the particular purpose. Failure to install this AKW product in accordance with supplied instructions or the making of unauthorised modifications will invalidate any warranty and may affect product safety. None of the foregoing affects your statutory rights.